

PRESSURE RELIEF VALVE WITH PROTECTIVE SHROUD

MODEL : T-6-LSM-SHB

1.0 FEATURES :

- Avoids disaster or injury to persons by providing Shroud.
- Avoids contamination of environment by providing shroud.
- A strong fabricated structure of MS for Shroud.
- Flanged connection from Shroud to drain pipe of 100 mm NB.
- Collection of spilled oil at safe place possible.
- Shroud can be rotated through 360° for connecting drain pipe.
- Reliable operation of PRV.
- Offers IP-67 ingress protection & C4-M Corrosion resistance.

2.0 PRODUCT DETAILS :

Pressure Relief Valve (PRV) is installed to protect oil filled transformer and similar electrical equipments when, due to any fault, the internal pressure rises above the safe limit. In the Model T-6-LSM-SHB, the PRV is provided with a fabricated Shroud which can be used to direct the discharge from the PRV to safe place by using 100 mm (4") NB pipe. The Shroud with flange avoids spilling of discharge from the PRV on all over the surrounding place. This avoids chances of fire and injury to the persons near transformer. To align with the drain pipe the Shroud can be rotated through 360 degrees. A Limit Switch is provided which initiates precautionary electric system when the PRV operates due to over pressure.

3.0 CONSTRUCTION AND WORKING :

The Model T-6-LSM-SHB, consists of a PRV and the Shroud as shown in Fig 1 & 3 of drawing. For mounting, 6 holes 14 diameter are provided on 235 PCD on the base of the PRV & Base of shroud. The working & operation of the PRV used in this application is same as standard Model T-6-LSM. However, the PRV for this application is slightly modified. The PRV has spring loaded diaphragm with 150 mm nominal port opening. For fixing Shroud on PRV, three S.S studs & nuts of M10 are provided along with three lugs. Suitable gaskets are provided to make all joints leak proof. The PRV with Shroud can be installed only on horizontal Top Plate of Transformer.

4.0 PACKING :

For convenience, PRV with gasket is packed in one box .The Shroud, Base Plate for Shroud & gaskets are packed in other box. Both PRV & Shroud are serially numbered. Please note, PRV & Shroud of same serial numbers should be installed together.

5.0 INSTALLATION :

The user has to provide leak proof Mounting Pad as per Fig.4 of drawing at suitable place on top cover of tank. The position should be selected such that the indicating Flag should be visible & at the same time wiring should be easy. Care should be taken to position the PRV so that the 100 mm NB drain pipe can be connected to the Shroud.

By tightening M12 bolts evenly, the PRV should be installed as shown in Fig.1 of drawing and photos on right side of this page. Then the Shroud should be assembled by using three Lugs. Gaskets should be placed as shown in drawing. The drain pipe should be connected to the flange of the Shroud. By removing the rain guard the wiring should be done as per the Fig. 2 of drawing.

6.0 TESTS :

Each PRV is tested for following Routine Tests

1. Operating test at specified pressure with Shroud by using air.
2. Leakage test, at 75% of specified pressure with Shroud by using air for 24 hours.
3. Switch operation test at specified pressure with Shroud by using air.

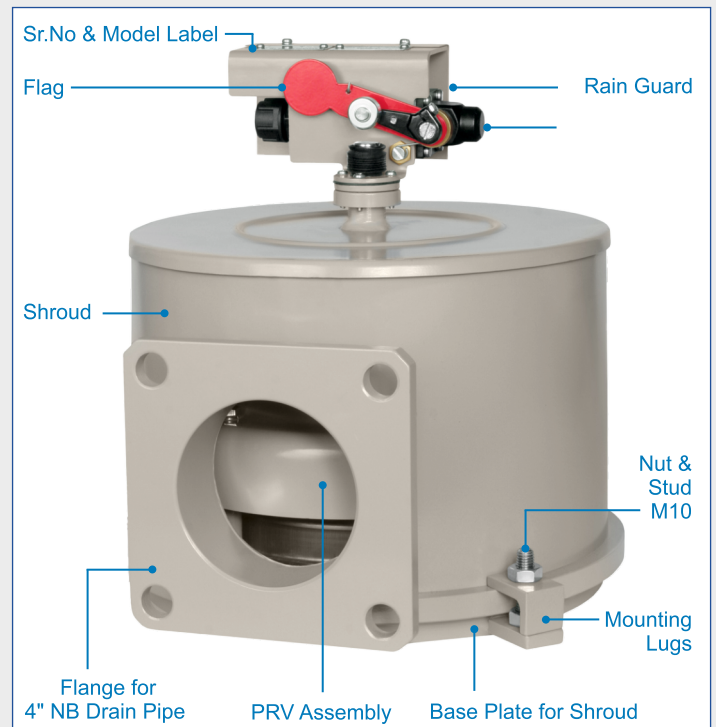

4. 2kV for one minute between live terminals and body.
5. IP-67 test carried at IDEMI, Mumbai.

7.0 FAULTS AND REMEDIES :

Only the Limit Switch can be replaced if necessary. For all other faults, the PRV with Shroud has to be returned to SUKRUT for repairs.

8.0 ROUTINE MAINTENANCE :

Periodically, every six months PRV should be tested by using compressed air to check satisfactory working. Switch operation also should be checked.

9.0 HOW TO ORDER :

Ask for quotation by informing the Model No. Operating Pressure & Contact requirement as per Fig. 2 of drawing. Order must be placed for PRV with Shroud.

10.0 GENERAL NOTES :

1. The Operating Pressure of PRV is not adjustable at site. Hence care should be taken at the time of specifying Operating Pressure.
2. The value of Operating Pressure should be worked out carefully considering strength of tank and existing static head of oil on PRV.
3. Storing of PRV should be done carefully. Passage of particles or small pieces through tank side of PRV will get trapped below the spring loaded diaphragm. This will cause continuous leakage of oil even at normal pressure in tank.
4. Care should be taken to install PRV Shroud of same Serial No.



PRESSURE RELIEF VALVE WITH PROTECTION SHROUD

MODEL : T-6-LSM-SHB

FIG. 1 : DETAILS OF ASSEMBLY

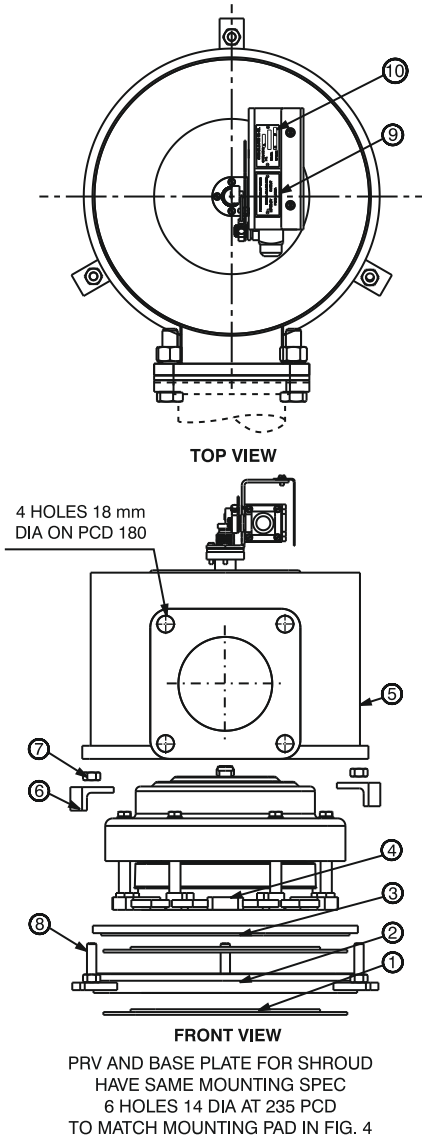
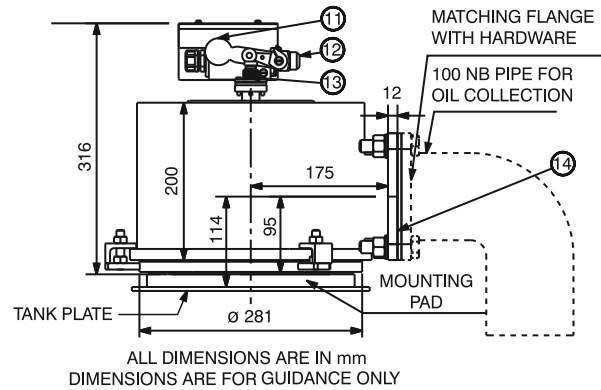

FIG. 3 : PRV AND SHROUD IN ASSEMBLED CONDITION



PART LIST FOR FIG. 1 & 3

SR NO.	DESCRIPTION	MATERIAL	QTY
1.	GASKET FOR BASE FOR SHROUD	NITRILE	2
2.	BASE PLATE FOR SHROUD	MS	1
3.	GASKET U SHAPE FOR BASE PLATE FOR SHROUD	NITRILE	1
4.	PRV SUB ASSEMBLY	—	1
5.	SHROUD	MS	1
6.	LUG FOR SHROUD	MS	3
7.	NUT M 10	SS	6
8.	STUD M 10	SS	3
9.	SR. NO. LABEL	SS	1
10.	PRODUCT LABEL	SS	1
11.	FLAG (RED COLOUR)	AL	1
12.	LIMIT SWITCH	BROUGHT OUT	1
13.	RUBBER BELOW	NITRILE	1
14.	FLANGE FOR 100 NB PIPE	MS	1

FIG. 4 : MOUNTING PAD

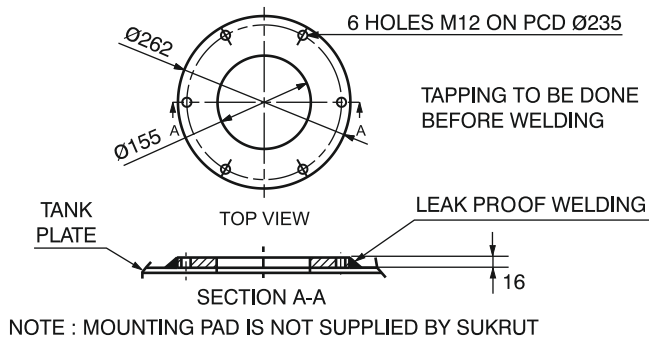
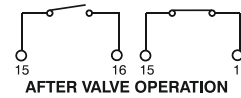
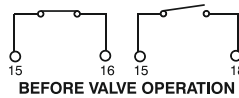
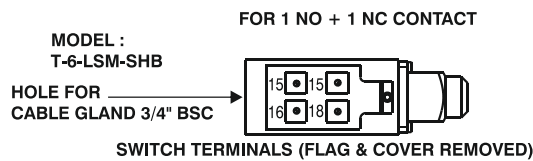
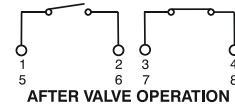
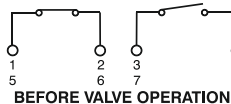
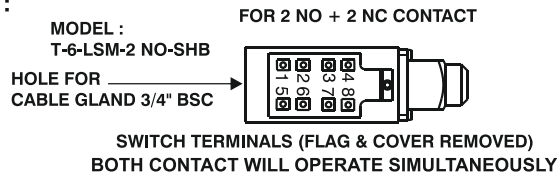

FIG. 2 A : WIRING DIAGRAM AND SWITCH OPERATION



CONTACT RATING : 5 A, 220 V AC
2.2 A, 220 V DC

FIG. 2 B :



SUKRUT ELECTRIC CO. PVT. LTD.

Plot No. Pap-B-63, MIDC Chakan Industrial Area Phase - II, Village Bhamboli, Taluka Khed District Pune 410 501, Maharashtra, India.

Mobile : +91 75077 78841 / 75077 78842

Email : marketing@sukrutelectric.com

Web : www.sukrutelectric.com

